

DRAWING	X.XX
TOLERANCE	±0.25

품번 No	부품명 PART NAME	수량 Q'TY	재질 MATERIAL	색상 COLOR	처리 FINISH	비고 REMARK
01	Housing	1	Thermoplastic			
02	Contact	11	Copper Alloy			
03	Shell	1	Stainless Steel			

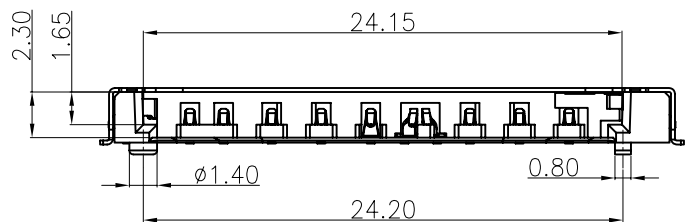
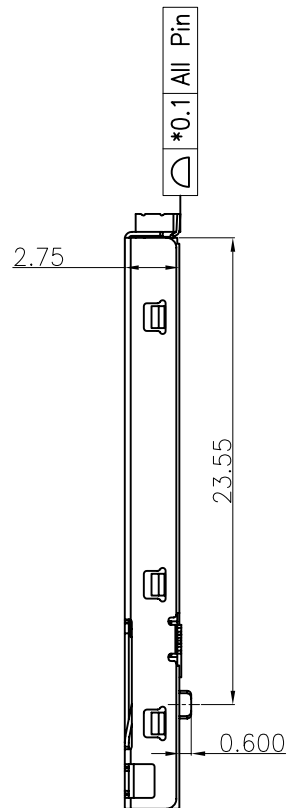
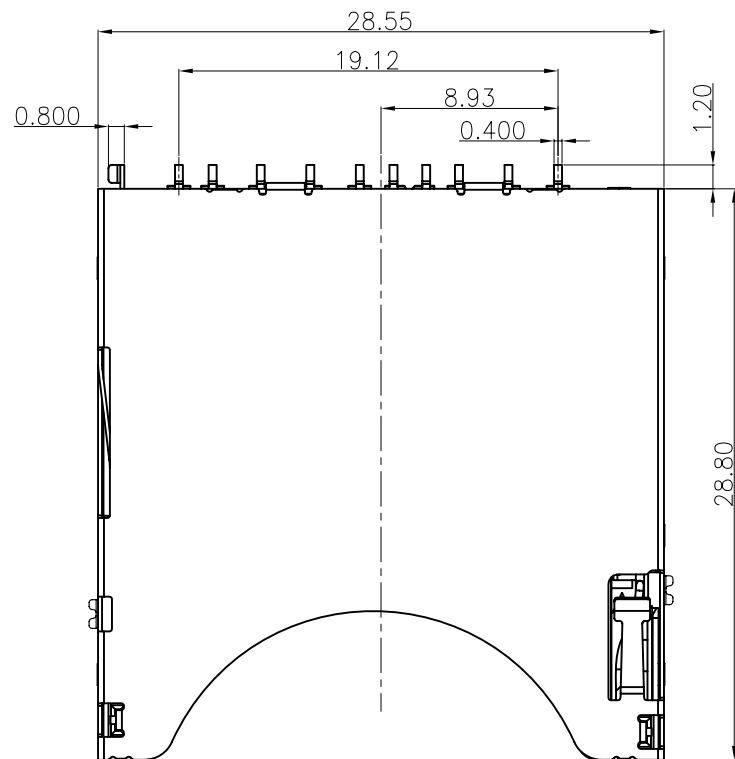

### Specification

- 1) MATERIAL:  
 Insulator: Thermoplastic (LCP),  
 UL 94V-0.  
 Contact: Copper Alloy (C5191)  
 Shell: Stainless Steel (SUS304)
- 2) PLATING:  
 Contact: Plated 50u" Ni Overall  
 Plated Au Selective Contact Area  
 Plated 100u" Sn Over Ni On Solder Area  
 Shell: Plated 50u" Ni Overall  
 Plated 1u" Au Over Ni On Solder Area
- 3) Usable Memory Card: SD&MMC Card
- 4) Type: Push-Push Type

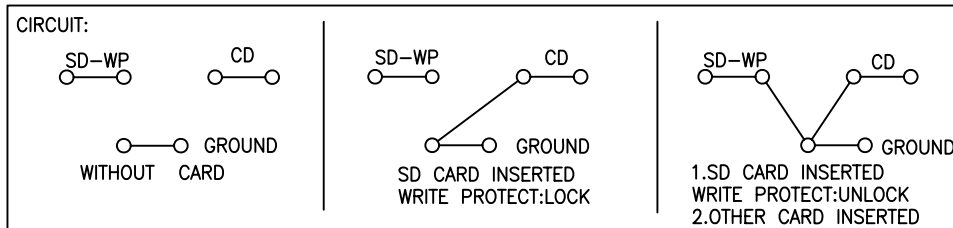

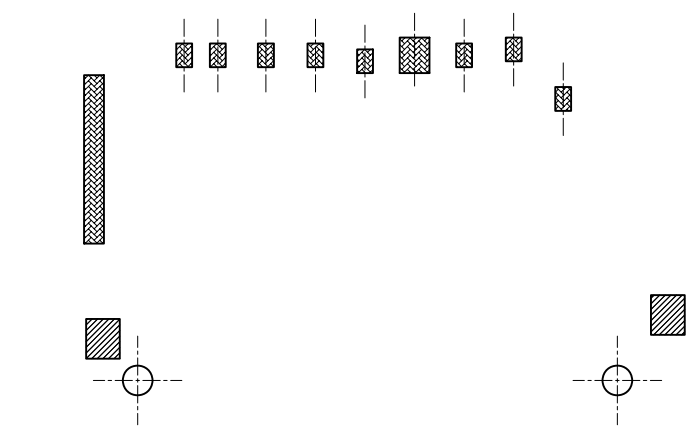
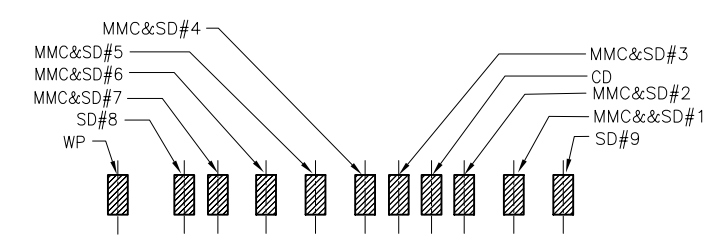

△					설계 DES'N BY	검도 CH'D BY	승인 APPROVE BY	작성일자 DWG DATE	모델명 MODEL NAME	SD CARD SOCKET	
								2011.07.27			
△								척도 SCALE	부품명 PART NAME	제품규격 STANDARD	
								1 / 1	ASSEMBLY		6210-10P
△								단위 UNITS	도번 DWG No	제품코드 ERP CODE	
No	내	용	작성일	작성자	승인	<b>CTC</b> Connection Technologies Corporation		mm			





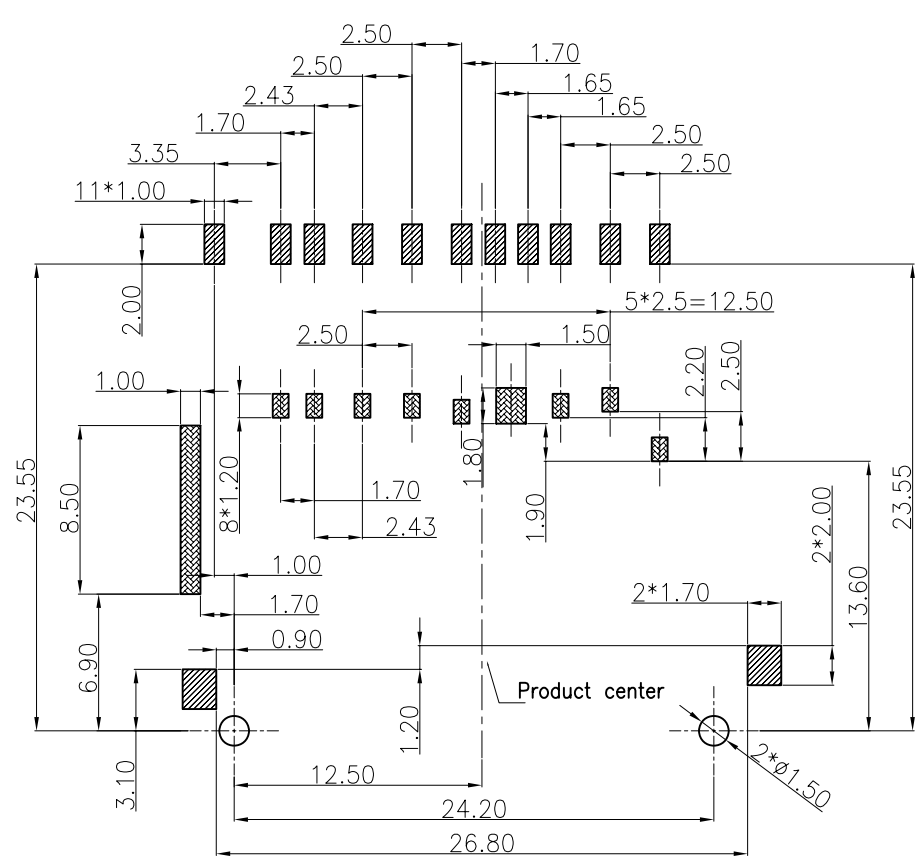

PIN NO.	MEMORY CARD PIN NO.
MMC&SD#1	MMC&SD#1 (CD/DAT3)
MMC&SD#2	MMC&SD#2 (CMD)
MMC&SD#3	MMC&SD#3 (VSS1)
MMC&SD#4	MMC&SD#4 (VDD)
MMC&SD#5	MMC&SD#5 (CLK)
MMC&SD#6	MMC&SD#6 (VSS2)
MMC&SD#7	MMC&SD#7 (DAT0)
SD#8	SD-8 (DAT1)
SD#9	SD-9 (DAT2)

### Recommend PCB Layout



 Welding area  
 prohibited layout area

    No	내	용	작성일	작성자	승인	설계 DES'N BY	검토 CH'D BY	승인 APPROVE BY	작성 일자 DWG DATE 2011.07.27	모델명 MODEL NAME SD CARD SOCKET	
							척도 SCALE 1 / 1	부품명 PART NAME ASSEMBLY	제품규격 STANDARD 6210-10P		
							<b>CTC</b> Connection Technologies Corporation	단위 UNITS mm	도번 DWG No	제품 코드 ERP CODE	

SD Card Insert

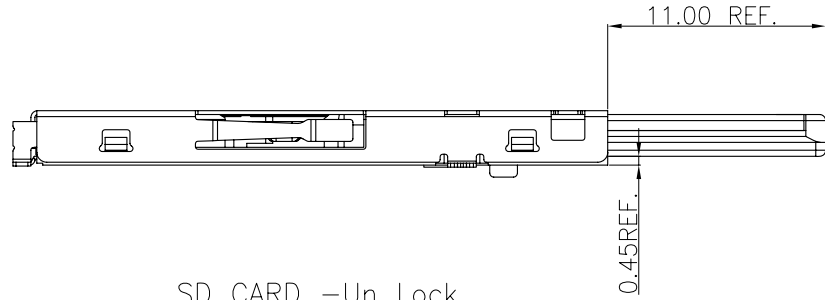

SD CARD -Un Lock

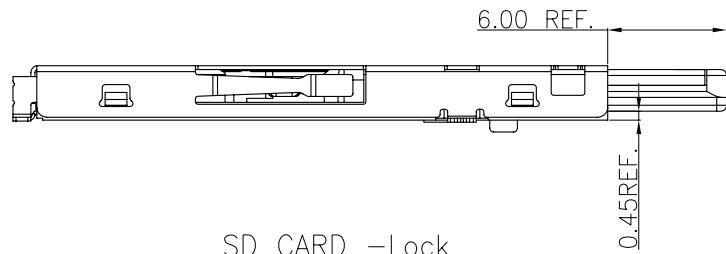

SD CARD -Lock

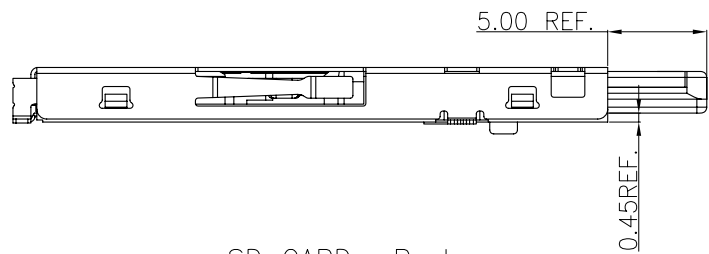

SD CARD -Push

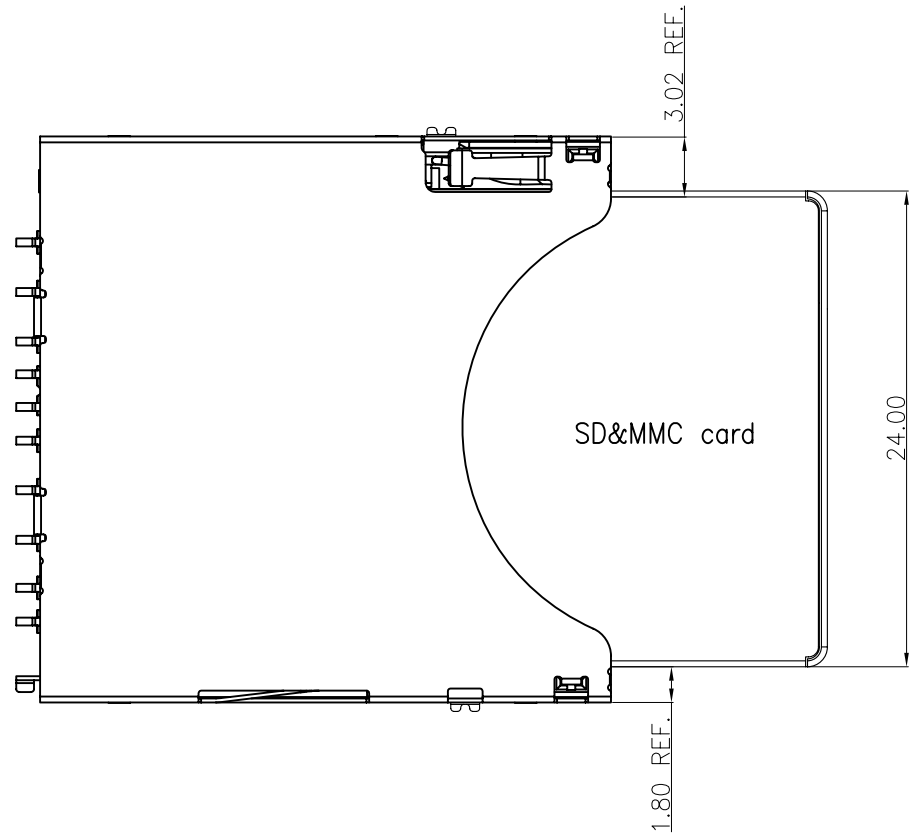

△ △ △ △ No					설 계 DES'N BY	검 도 CH'D BY	승 인 APPROVE BY	작성 일자 DWG DATE 2011.07.27	모델명 MODEL NAME SD CARD SOCKET	
								척 도 SCALE 1 / 1	부품명 PART NAME ASSEMBLY	제품규격 STANDARD 6210-10P
								단 위 UNITS mm	도 번 DWG No	제품 코드 ERP CODE
		내	용	작성 일	작성 자	승 인	<b>CTC</b> Connection Technologies Corporation			

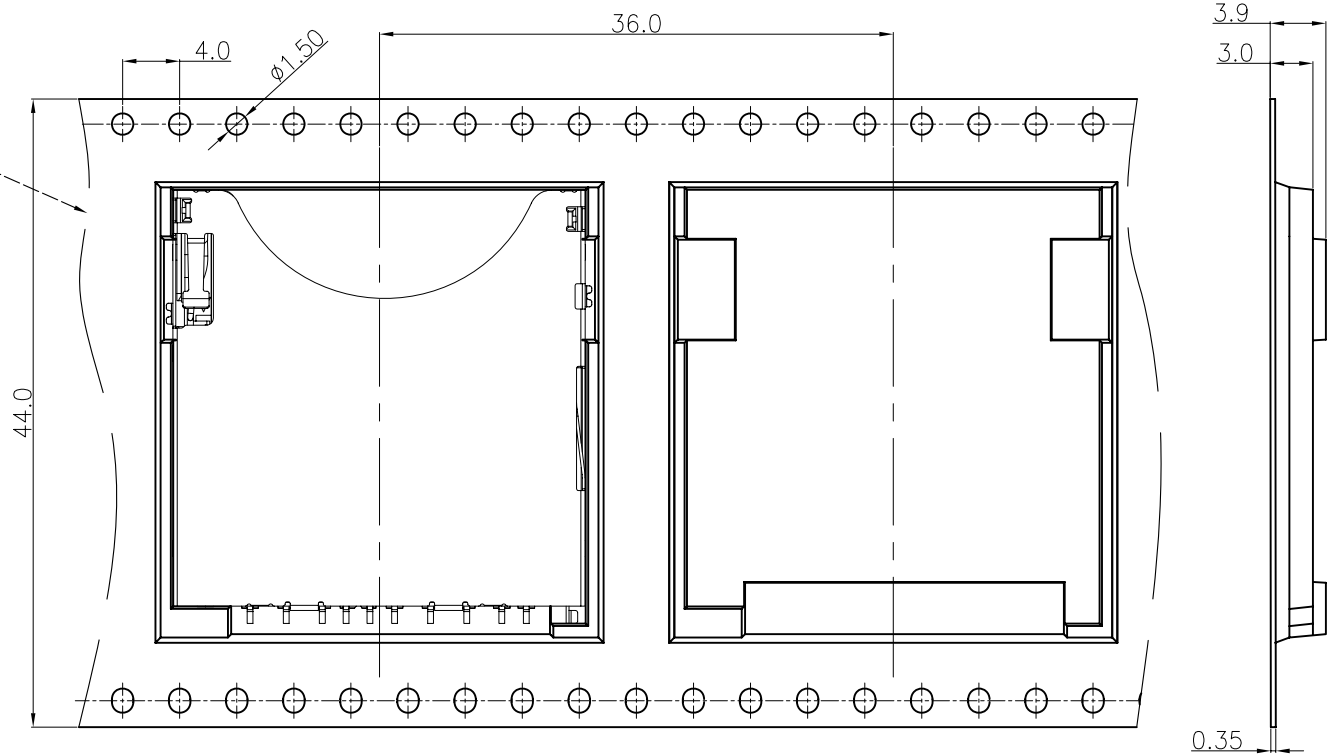
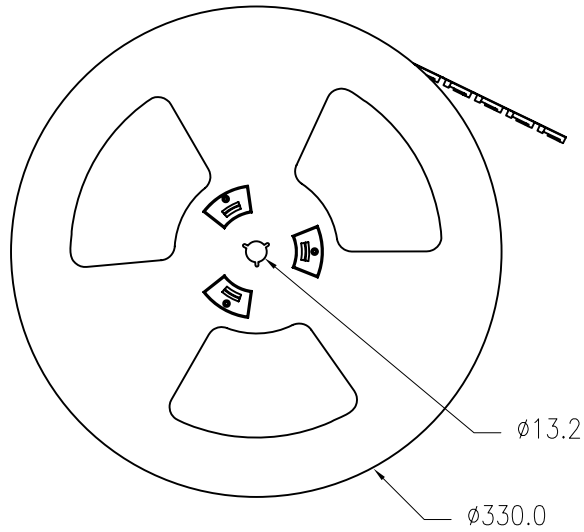
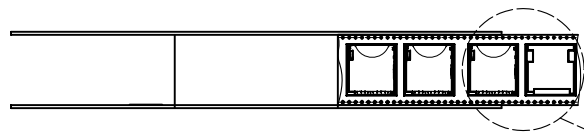

PACKING

1. QUANTITY OF PER TAPE REEL: 400 PCS
2. QUANTITY OF PER CARTON: 5 TAPE REEL
3. QUANTITY OF PER CARTON: 2,000 PCS

△ △ △ △ No					설 계 DES'N BY	검 도 CH'D BY	승 인 APPROVE BY	작성 일자 DWG DATE 2011.07.27	모델명 MODEL NAME SD CARD SOCKET	
								척 도 SCALE 1 / 1	부품명 PART NAME ASSEMBLY	제품규격 STANDARD 6210-10P
								단 위 UNITS mm	도 번 DWG No	제품 코드 ERP CODE
		내 용	작성 일	작성 자	승 인	<b>CTC</b> Connection Technologies Corporation				